

Nikon

Stereoscopic Zoom Microscope

SMZ1500



Superb optical performance and ease of operation
that sets a new standard for stereoscopic zoom microscopes
in the 21st century.



There are three prerequisites that are incorporated into the design of Nikon products: 1) superb optical performance; 2) superior quality and reliability; and 3) customer satisfaction.

Superb optical performance is a matter of course at Nikon, a company that has been a leader in the optical industry for more than 75 years.

Superior quality and reliability are fundamental concepts that permeate the very heart of Nikon in a rapidly changing world that continues to shape new products and how they are used.

The third prerequisite, customer satisfaction, is of course the ultimate goal of Nikon and the direct result of the first two.

With the development of the SMZ1500, however, a fourth prerequisite has been set: developing a standard for the new century. All the specifications and current levels of performance in stereoscopic zoom microscopes were reviewed from the bottom up to establish a standard that will extend into the 21st century. Just look at the SMZ1500's zoom ratio of 15X, the highest* in the world, its unparalleled optical performance, and Nikon's Oblique Coherent Contrast (OCC) illumination system.

Welcome to the birth of a new century . . . and the birth of a new standard: the SMZ 1500 stereoscopic zoom microscope.

* True for stereoscopic zoom microscopes as of February 2000.

Samples appear sharp and undistorted, thanks to Nikon's superb optical technology



From left to right: P-HR Plan Apo 1X, P-HR Plan Apo 1.6X, and P-HR Plan Apo 0.5X



Diatom

New objectives feature higher N.A.'s and exceptional resolving power

In pursuit of sharper and brighter images, Nikon has developed a series of objectives featuring higher N.A.'s and incredible resolving power. For example, the P-HR Plan Apo 1.6X objective* delivers an N.A. of 0.21 and a resolving power of 630 lines/mm. These superb objectives feature optimum contrast and a minimum of flare across the entire view field out to the edges.

*Patent pending in Japan

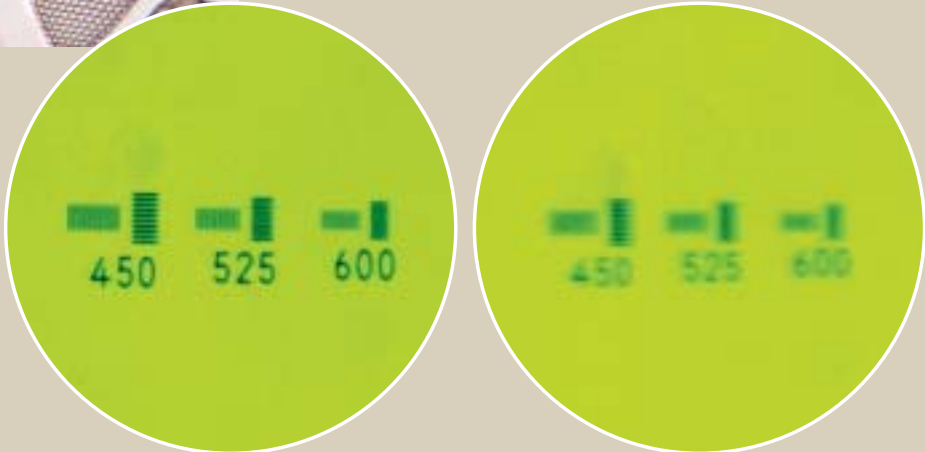

SMZ1500

Conventional model

Comparison of resolving power

Images appear undistorted and natural-looking

Producing images that cause less strain on your eyes was one goal of Nikon's ergonomic design. We tackled the problems usually associated with stereoscopic microscopes, such as surface irregularities and the apparent bulging of objects, and solved these to a high degree by minimizing the distortion in these lenses. Now you can view stereoscopic images that appear natural-looking right out to the periphery.

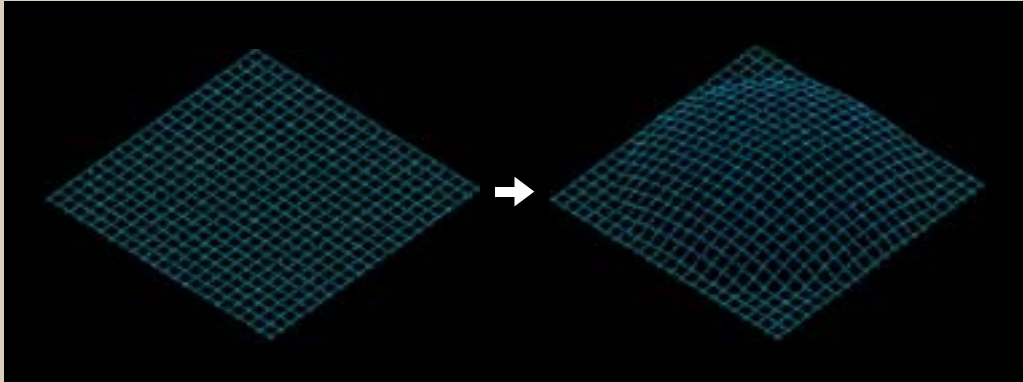

Distortion causes a globular effect as shown above even when you actually observe a flat object.



Image where chromatic aberration has been corrected in the SMZ1500

Successful correction of chromatic aberration

Nikon's approach to reducing chromatic aberration extends from just the right choice of optical glass to the optical design itself, resulting in a high degree of correction for axial and lateral chromatic aberrations. Although reducing chromatic aberrations and eliminating distortion were traditionally thought to be extremely difficult, Nikon has succeeded brilliantly, producing stereoscopic images with true-to-life colors.



Image that exhibits chromatic aberration.

Comparison of chromatic aberrations

Ultrahigh magnification and exceptionally large zoom ratio provide observations that are state-of-the-art.

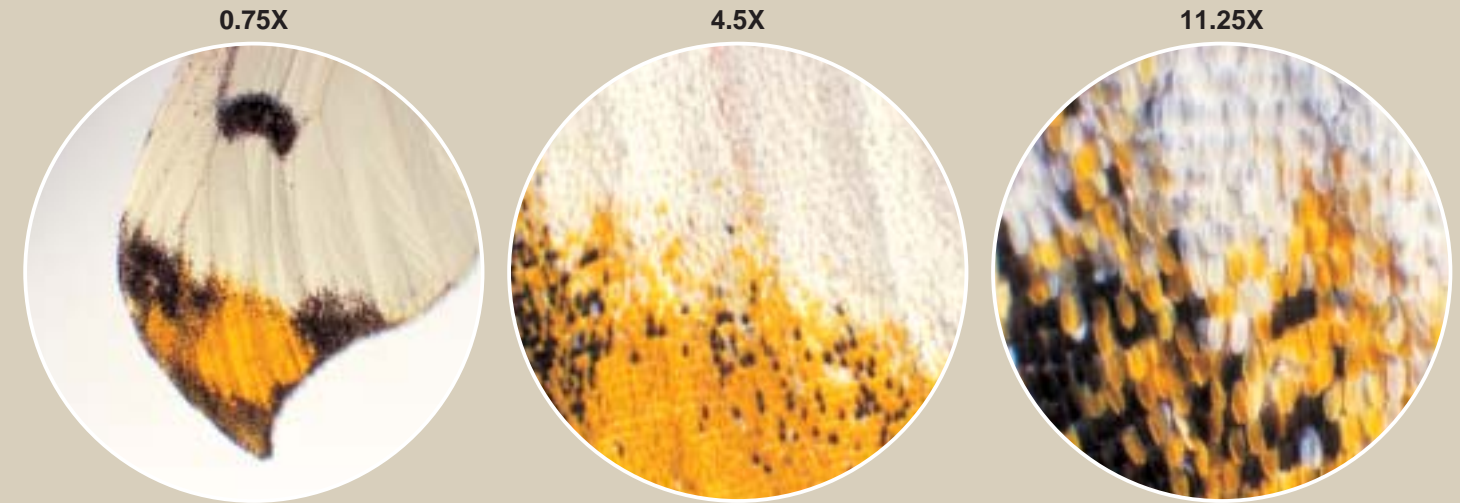

Comparison of view fields by zoom ratio and magnification

World's largest zoom ratio of 15X

The culmination of Nikon's leading-edge optical technologies, the SMZ1500 features the world's largest zoom ratio of 15X covering a range from 0.75X to 11.25X. This extraordinary range makes changing lenses unnecessary, allowing you to concentrate on observations.

Unbelievably wide range of magnifications

Depending on the combination of eyepiece and objective chosen, the SMZ1500 provides a total magnification range from 3.75X to 540X. This allows you to select the best magnification to match your application, extending from the macro to the micro range.



High-eyepoint eyepieces with built-in diopter adjustment

All eyepieces are the high eyepoint-type and have a wide field of view; for example, the C-W10X is 22mm. In addition, these eyepieces have built-in diopter adjustment, so the image and the reticle are brought into focus at the same time, making viewing easy, while reducing eyestrain.



The zooming knob features click-stops at 1X intervals from 1X to 11X, eliminating the need to remove your eyes from the eyepiece while changing magnification.

Built-in aperture diaphragm

The SMZ1500 comes with a built-in aperture diaphragm that is useful for observation and photomicrography or CCTV monitoring. Optimum depth of focus can also be achieved by adjusting this diaphragm.



Ergonomic design to provide operational comfort

Comparison of observation postures

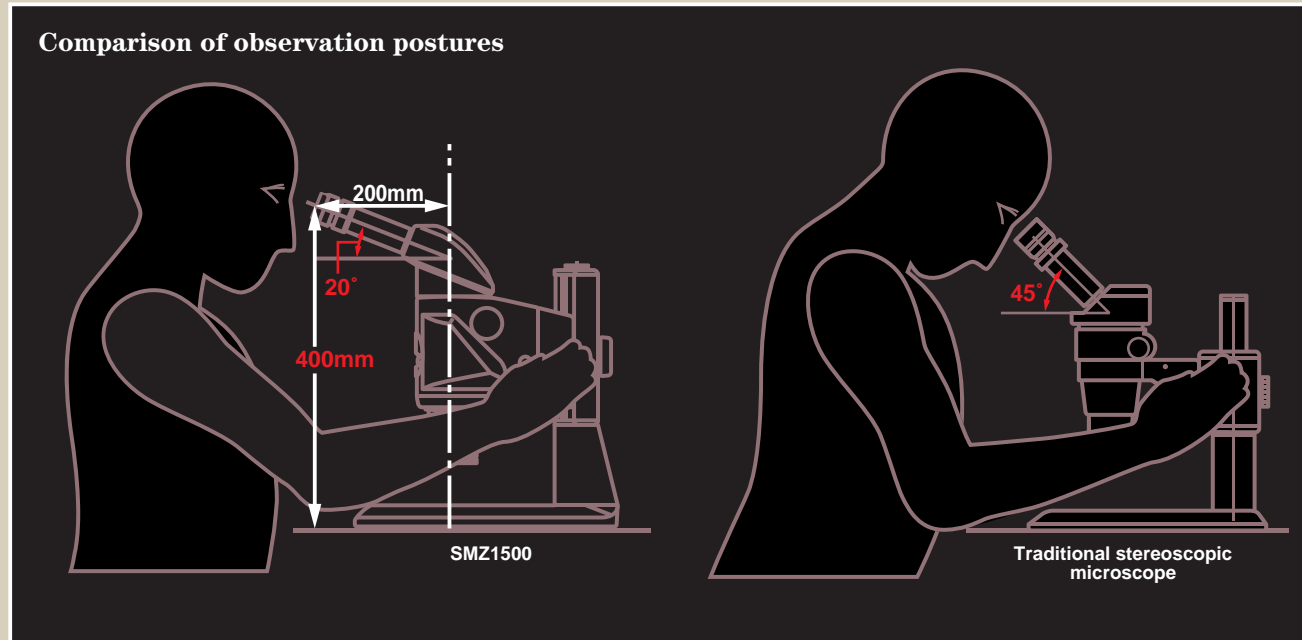

Standard eyepiece tube inclined 20°

The standard binocular eyepiece tube is inclined 20°, allowing you to observe samples without having to lean forward. This reduces fatigue during long hours of operation by reducing strain on your neck, shoulders, and back.



①Standard binocular eyepiece tube, ②Low eye-level eyepiece tube, ③Tilting eyepiece tube, ④Eye-level riser

In addition to the standard type, you have the option of using other eyepiece tubes and/or eye-level risers to obtain the optimum eyepoint, depending on your height or whether or not an intermediate tube is inserted.

Low-eye-level eyepiece tube

The low eye-level binocular eyepiece tube enables comfortable observation even when using a diascopic stand or when an intermediate tube is inserted.

Tilting eyepiece tube

The tilting binocular eyepiece tube allows continuous adjustment of the eyepiece inclination from 0° to 30°. You can also adjust the eye level a maximum of 157mm (6.2") by swinging the eyepieces up 180° and tilting them.

Eye-level riser

Lets you increase the eyepoint height 25mm per riser for a total of 50mm.



With the tilting eyepiece tube, the eye level can be adjusted a maximum of 157mm (6.2").

Coaxial coarse/fine focusing unit—especially useful at high magnifications

The SMZ1500 comes with a coaxial coarse/fine focusing unit that travels smoothly along the optical axis. Its new anti-backlash mechanism* makes fine adjustment of focus easier and more accurate. A built-in counterbalance ensures easy movements even when a weighty attachment such as a photomicrographic system is mounted. Furthermore, the focus knob is soft to the touch and located in a comfortable, low position.

* Patent pending in Japan



Accurate focusing is easy, thanks to an anti-backlash mechanism that uses three concentric planetary gears with built-in springs.

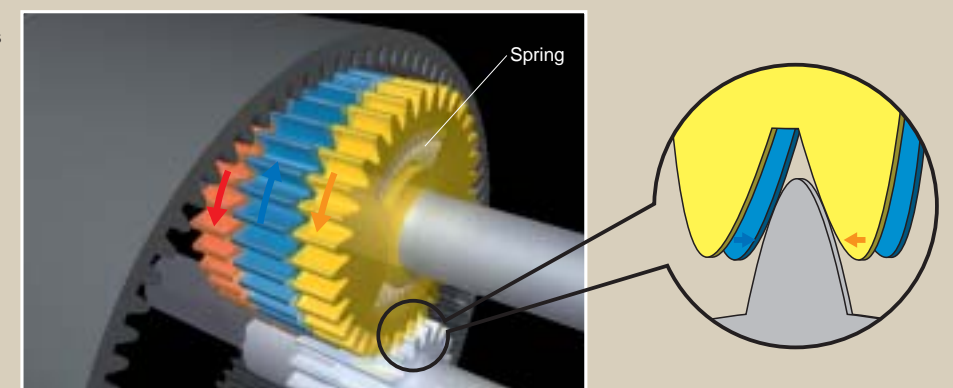

Anti-backlash mechanism

Top-notch features and functions are easier to use.

Large, streamlined base ensures easy operation

The C-PS160 Plain Stand features a low profile for easy handling of samples. Also, its stage plate is 180mm (7.1") wide, while the distance between the optical axis and the pillar is 160mm (6.3"). In addition to this large clearance, the base has a wide front and smooth curves, so you can rest your arms while working.



Diascopic stands are now easier to use

The new Diascopic Stands, models C-DSD, C-DSS, and C-BD, each have a built-in power supply in a space-saving design. These stands also feature their own fine focus knob* at the front of the streamlined base—in addition to the one at the focusing mount—to make critical adjustment of focus much easier, especially during micromanipulations. Furthermore, their stage glass diameter is a generous 180mm (7.1"), making it possible to view samples in large Petri dishes all the way out to the periphery.

* Patent pending in Japan

System Diagram

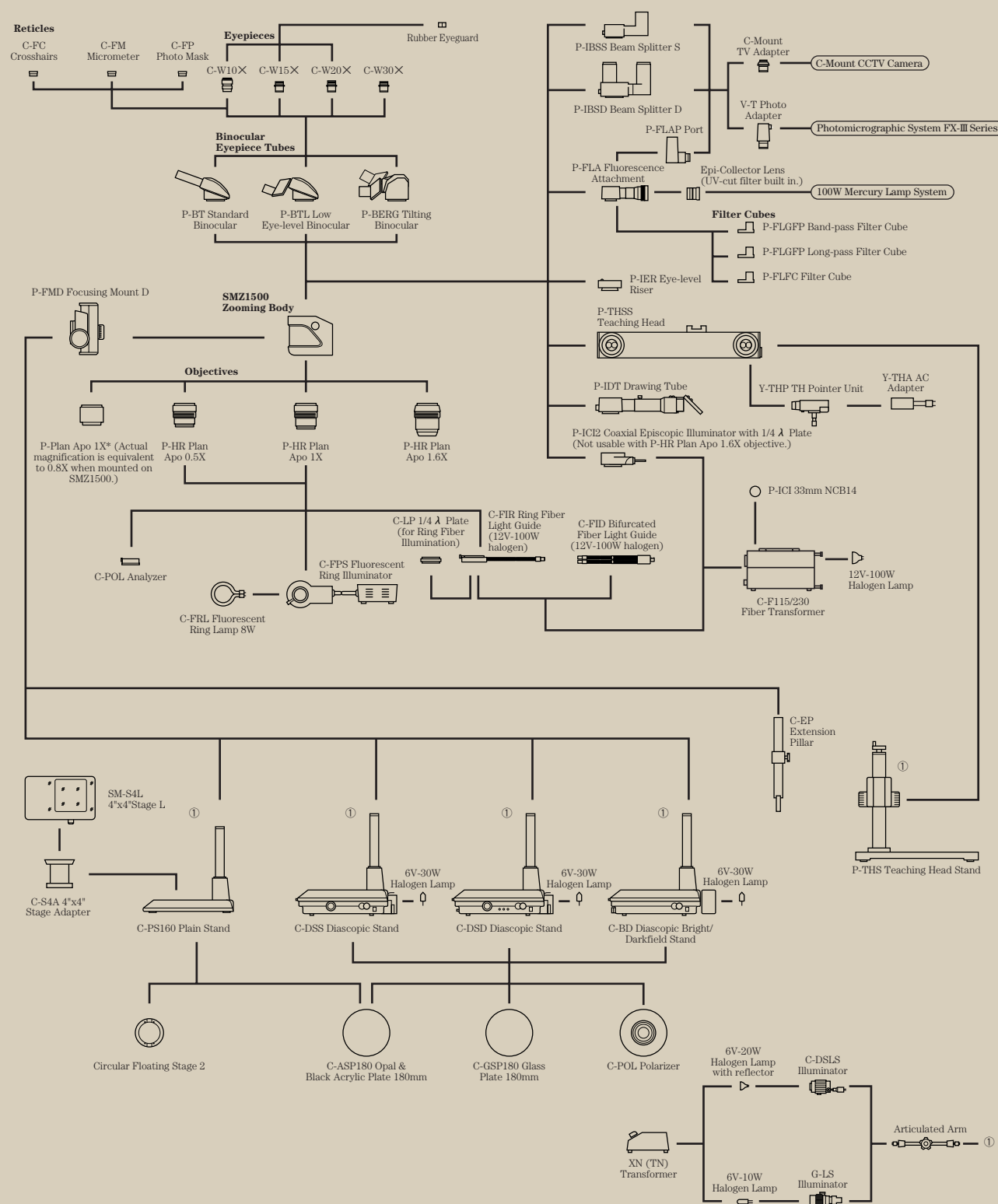

*Usable at zoom magnifications larger than 1.25X.

Flexible configuration plus a wide variety of accessories support a broad range of uses.

Three new diascopic stands

These new diascopic stands, models C-DSD, C-DSS, and C-BD, each have a 6V-30W halogen lamp with its own built-in power supply. Although their power supplies are built in, they are designed to keep the surface temperature at a low level, creating an environment

ideal for living specimens that are sensitive to rises in temperature. An adapter* for the 12V-100W fiber-optics light source is also available.

* Under development

High-end diascopic stand is ideal for low contrast specimens

The high-end C-DSD Diascopic Stand features condenser lenses that can be switched between low and high magnifications and allows high N.A. objectives to take advantage of the full potential of their superior resolving power. Furthermore, to answer user requests for high-contrast illumination, Nikon developed the Oblique Coherent Contrast (OCC) Illumination system*, allowing colorless and transparent samples to be observed in high relief.

* Patent pending in Japan



C-DSD Diascopic Stand (with OCC illumination system)

Diascopic bright/darkfield stand delivers high contrast

The C-BD Diascopic Bright/Darkfield Stand uses a seven-sided toroidal mirror* to reduce stray light** substantially. This stray light would ordinarily cause a decrease in contrast when using short-working distance objectives under darkfield diascopic illumination. But with the C-BD stand, the resulting images have a sufficiently high S/B (signal to background) ratio.

* Patent pending in Japan

** Up to 1/5 that of conventional equipment



C-BD Diascopic Bright/Darkfield Stand

The operating principle of the high-contrast darkfield illuminator using a toroidal mirror

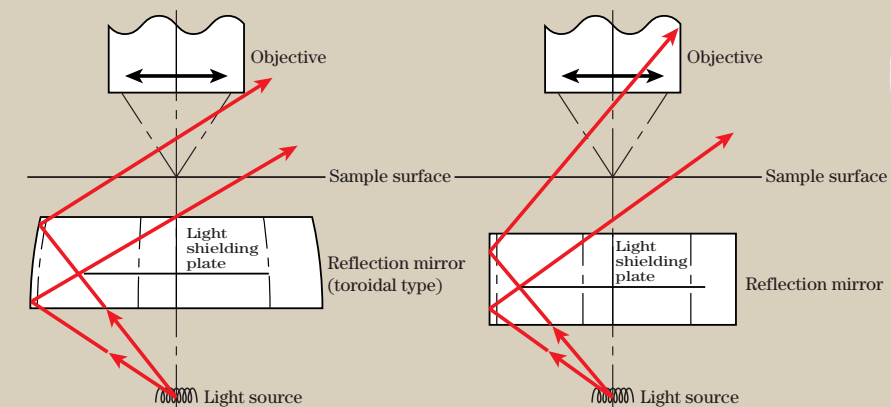

The toroidal mirror shields direct light coming from the light source.

SMZ1500

A small amount of direct light leaking from the light source enters the objective, reducing the contrast.

Conventional model

The operating principle of the OCC illumination system

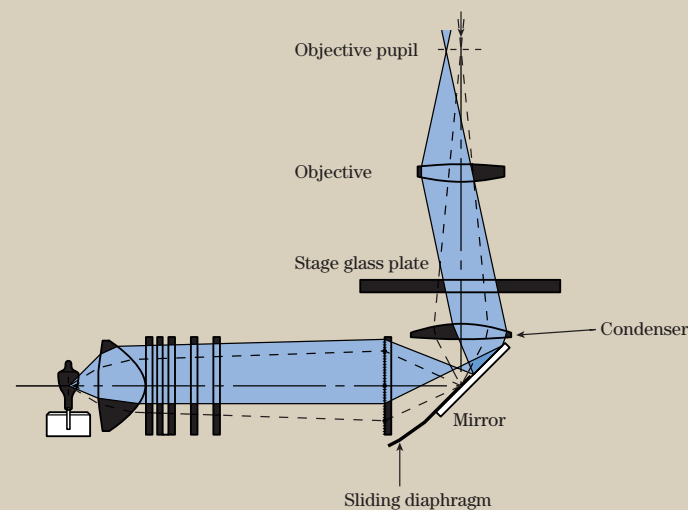

In Nikon's OCC illumination system, the center of the light beam is shielded by the sliding diaphragm placed in a position opposite the objective pupil, allowing coherent light to be projected obliquely onto the sample to produce high contrast.



Application example of the OCC Illuminator



Condenser changeover lever

Standard diascopic stand

The standard C-DSS Diascopic Stand has a light source and a power supply built into its simple body. Obtaining optimum contrast is easy by adjusting the angle of the built-in mirror with the knob.



C-DSS Diascopic Stand

For sophisticated observation techniques, photomicrography, or digital imaging.



Epi-fluorescence attachment

Nikon developed an epi-fluorescence attachment—model P-FLA—for stereoscopic microscopes that allows easy observation of living cells under the fluorescence method such as GFP. Switching between the fluorescence method and brightfield method is quick and easy.

Four filter blocks can be switched using a slide lever. If you add an optional photo port to this attachment, you can mount a photomicrographic system or a CCTV camera without using a beam splitter. Because 100% of the light is delivered to the photo port, bright images are ensured.

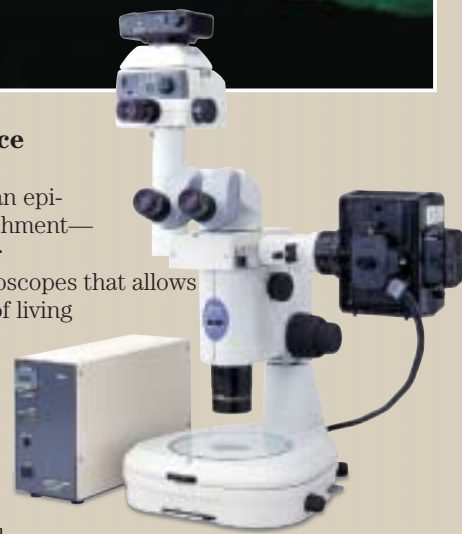

SMZ1500 configured with the epi-fluorescence attachment

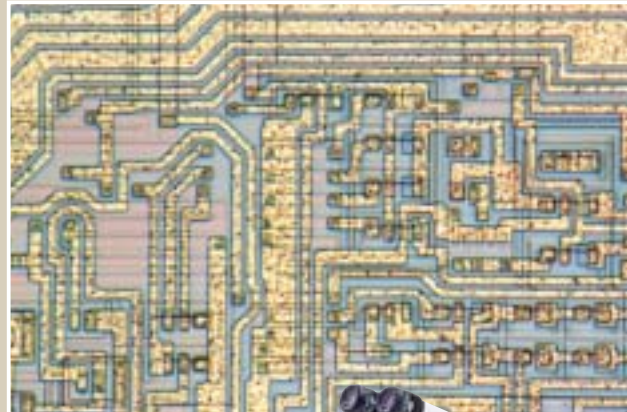

Coaxial episcopic illuminator

This illuminator—model P-ICI2—uses a 12V-100W fiber-optics light source—the same light source used in fiber illuminators—to deliver bright illumination over the entire sample surface. The thickness of the $1/4 \lambda$ plate has been reduced, minimizing spherical aberrations in high N.A. objectives.



SMZ1500 configured with the coaxial episcopic illuminator

Photomicrography or monitoring

By using a beam splitter and adapter, an FX-III Series photomicrographic system, a CCTV camera, or a digital still camera can be attached. The P-IBSD Beam Splitter D has two ports allowing one photomicrographic system and one CCTV camera to be mounted at the same time. The light to the rear port can be switched between 0%, 50%, or 100%, and the light to the side port is switchable between 0% or 50%. With the P-IBSS Beam Splitter S, the light to the side port is switchable between 0% or 50%.

Beam-split ratios

Beam splitter	Observation		Photomicrography	
	Left	Right	Rear port	Side port
P-IBSD	100%	100%	0%	0%
	0%	100%	100%	0%
	50%	50%	50%	50%
P-IBSS	100%	100%	—	0%
	100%	50%	—	50%



P-IBSS Beam Splitter installed in SMZ1500



P-IBSD Beam Splitter installed in SMZ1500

4"x4" stage

Used in combination with an optional extension pillar, the 4"x4" stage allows precise movement in the XY direction, making fine alignment easy during high magnification observations.



Flexible configuration

You can add other accessories such as thermo-plates and micromanipulators, depending on your needs.



Thermo-plate made by TOKAI HIT mounted on SMZ1500.

Various illuminators

Various kinds of illuminators such as a Plastic Fiber-Optic Ring Illuminator, Plastic Fiber-Optic Bifurcated Illuminator, 6V-10W/20W Halogen Illuminator, or a Fluorescent Ring Illuminator can be used to meet your applications.



Teaching head and drawing tube

For teaching purposes or when two or more colleagues are working as a team, a side-by-side teaching head, the P-THSS, is available. The P-IDT drawing tube is also attachable.



SMZ1500 configured with Narishige micromanipulators.



SMZ1500 configured with the plastic fiber-optic ring illuminator



SMZ1500 configured with the plastic fiber-optic bifurcated illuminator

Dimensions

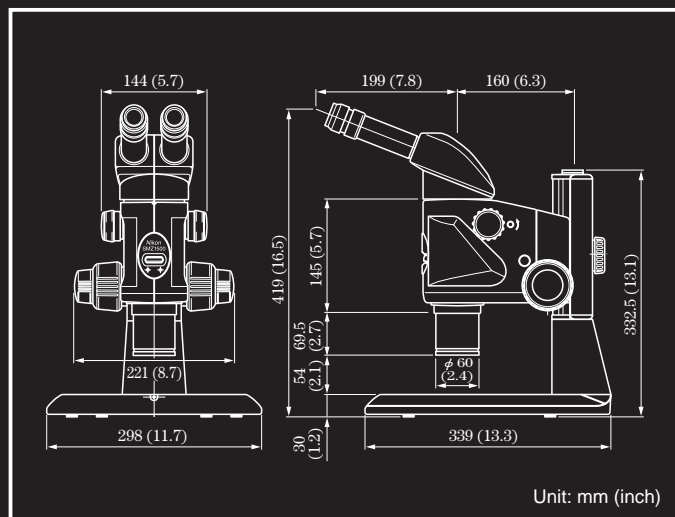

Magnification, Actual Field of View, Working Distance

Objectives	N.A./W.D. (mm)	Eyepieces							
		10X eyepiece C-W10X (F.N. 22), Reticle (dia. ø25mm)		15X eyepiece C-W15X (F.N. 16), Reticle (dia. ø19mm)		20X eyepiece C-W20X (F.N. 12.5), Reticle (dia. ø19mm), Magnification 1.3X		30X eyepiece C-W30X (F.N. 7), Reticle (dia. ø12mm), Magnification 1.4X	
		Total magnification	F.O.V. (ømm)	Total magnification	F.O.V. (ømm)	Total magnification	F.O.V. (ømm)	Total magnification	F.O.V. (ømm)
P-HR Plan Apo 0.5X	0.066/136	3.8–56.3X	58.7–3.9	5.6–84.4X	42.7–2.8	7.5–112.5X	33.3–2.2	11.3–168.8X	18.7–1.2
P-HR Plan Apo 1X	0.131/54	7.5–112.5X	29.3–2.0	11.3–168.8X	21.3–1.4	15.0–225.0X	16.7–1.1	22.5–337.5X	9.3–0.6
P-HR Plan Apo 1.6X	0.21/24	12.0–180.0X	18.3–1.2	18.0–270.0X	13.3–0.9	24.0–360.0X	10.4–0.7	36.0–540.0X	5.8–0.4
P-Plan Apo 1X	0.1/70	6.0–90.0X	36.7–2.4	9.0–135.0X	26.7–1.8	12.0–180.0X	20.8–1.4	18.0–270.0X	11.7–0.8

Specifications

Optical system	Parallel-optics zoom system
Total magnification	3.75X–540X (Depending on eyepiece and objective used.) (When coaxial episcopic illuminator is attached: 5.6X–506X)
Eyepiece tubes	P-BT Standard Binocular, P-BTL Low Eye-level Binocular, P-BERG Tilting Binocular
Eyepiece inclination	20° (Standard Binocular and Low Eye-level Binocular), 0°–30° (Tilting Binocular)
Interpupillary distance adjustment	48–75mm (1.9–3.0 in.)
Eyepieces (with diopter adjustment)	C-W10X (F.N. 22), C-W15X (F.N. 16), C-W20X (F.N. 12.5), C-W30X (F.N. 7)
Zoom range	0.75X–11.25X
Zoom ratio	15 : 1
Objectives	P-HR Plan Apo 0.5X, 1X, 1.6X; P-Plan Apo 1X
Working distance	Please refer to the table at left.
Illumination systems	P-ICI2 Coaxial Episcopic Illuminator (12V-100W halogen) (Intermediate magnification is 1.5X.) G-LS 6V-10W Illuminator (with Articulated Arm) C-DSLS 6V-20W Illuminator (with Articulated Arm) C-FPS Fluorescent Ring Illuminator C-FIR Plastic Fiber-optic Ring Illuminator (12V-100W halogen) C-FID Plastic Fiber-optic Bifurcated Illuminator (12V-100W halogen)
Stands	C-PS160 Plain Stand C-DSS Diascopic Stand C-DSD Diascopic Stand C-BD Diascopic Bright/Darkfield Stand P-THS Teaching Head Stand
Photomicrographic/CCTV system	Nikon Photomicrographic System FX-III Series or CCTV camera can be attached through Beam Splitter and Adapter. Photo-tube beam-split ratio: please refer to the table on page 15.
Power consumption	Diascopic stands: 80W C-FPS115 Fluorescent Ring Illuminator: 24W C-FPS230 Fluorescent Ring Illuminator: 16W Fiber Transformer: 135W

Note: For possible combinations of accessories, please refer to the system diagram on page 11.

Specifications and equipment are subject to change without any notice or obligation on the part of the manufacturer. April 2002. ©2000/01 NIKON CORPORATION

	WARNING	TO ENSURE CORRECT USAGE, READ THE CORRESPONDING MANUALS CAREFULLY BEFORE USE.
--	----------------	---

NIKON INSTECH CO., LTD.

Parale Mitsui Bldg., 8, Higashida-cho, Kawasaki-ku, Kawasaki, Kanagawa 210-0005, Japan
phone: +81-44-223-2175 fax: +81-44-223-2182
<http://www.ave.nikon.co.jp/inst/>

NIKON SINGAPORE PTE LTD

SINGAPORE phone: +65-5593618 fax: +65-5593668

NIKON MALAYSIA SDN. BHD.

MALAYSIA phone: +60-3-78763887 fax: +60-3-78763387

NIKON INSTRUMENTS EUROPE B.V.

P.O. Box 222, 1170 AE Badhoevedorp, The Netherlands
phone: +31-20-44-96-222 fax: +31-20-44-96-298

NIKON FRANCE S.A.

FRANCE phone: +33-1-45-16-45-16 fax: +33-1-45-16-00-33

NIKON GMBH

GERMANY phone: +49-211-9414-0 fax: +49-211-9414-322

NIKON INSTRUMENTS S.p.A.

ITALY phone: +39-55-3009601 fax: +39-55-300993

NIKON AG

SWITZERLAND phone: +41-1-913-62 00 fax: +41-1-910-37 44

NIKON UK LTD.

UNITED KINGDOM phone: +44-20-8541-4440 fax: +44-20-8541-4584

NIKON INSTRUMENTS INC.

1300 Walt Whitman Road, Melville, N.Y. 11747-3064, U.S.A.

phone: +1-631-547-8500; +1-800-52-NIKON (within the U.S.A. only) fax: +1-631-547-0306

<http://www.nikonusa.com/>

NIKON CANADA INC.

CANADA phone: +1-905-625-9910 fax: +1-905-625-0103

